



# Regulated, 125mA-Output, Charge-Pump DC-DC Inverter

MAX1673

## General Description

The MAX1673 charge-pump inverter provides a low-cost, compact means of generating a regulated negative output from a positive input at up to 125mA. It requires only three small capacitors, and only two resistors to set its output voltage. The input range is 2V to 5.5V. The regulated output can be set from 0V to  $-V_{IN}$  in Skip regulation mode or  $-1.5V$  to  $-V_{IN}$  in Linear (LIN) regulation mode.

In Skip mode, the MAX1673 regulates by varying its switching frequency as a function of load current. This On-Demand™ switching gives the MAX1673 two advantages: very small capacitors and very low quiescent supply current. At heavy loads, it transfers energy from the input to the output by switching at up to 350kHz. It switches more slowly at light loads, using only 35 $\mu$ A quiescent supply current.

In Linear mode, the MAX1673 switches at a constant 350kHz at all loads and regulates by controlling the current-path resistance. This provides constant-frequency ripple, which is easily filtered for low-noise applications.

This device also features a 1 $\mu$ A logic-controlled shutdown mode and is available in a standard 8-pin SO package. For a device that delivers about 10mA and fits in a smaller package, refer to the MAX868.

## Applications

|                                       |                         |
|---------------------------------------|-------------------------|
| Hard Disk Drives                      | Measurement Instruments |
| Camcorders                            | Modems                  |
| Analog Signal-Processing Applications | Digital Cameras         |

## Pin Configuration

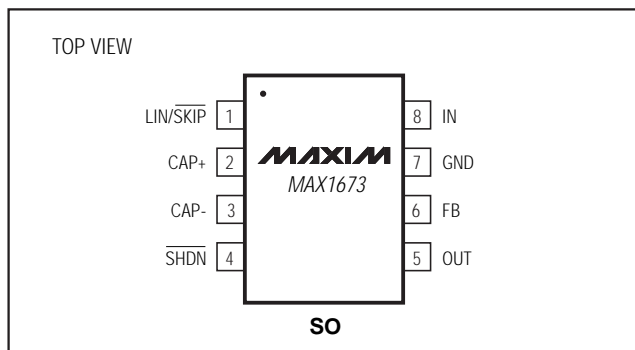

On-Demand™ is a trademark of Maxim Integrated Products.

## Features

- ◆ Regulated Negative Output Voltage (up to  $-1 \times V_{IN}$ )
- ◆ 125mA Output Current
- ◆ 35 $\mu$ A Quiescent Supply Current (Skip-mode regulation)
- ◆ 350kHz Fixed-Frequency, Low-Noise Output (Linear-mode regulation)
- ◆ 2V to 5.5V Input Range
- ◆ 1 $\mu$ A Logic-Controlled Shutdown

## Ordering Information

| PART       | TEMP. RANGE    | PIN-PACKAGE |
|------------|----------------|-------------|
| MAX1673ESA | -40°C to +85°C | 8 SO        |

## Typical Operating Circuit

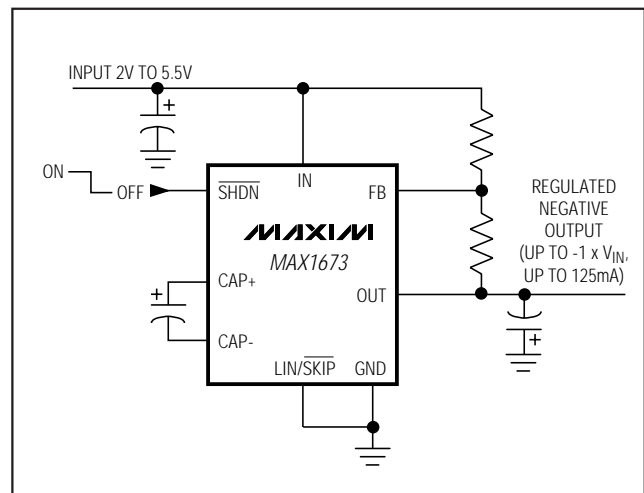

# Regulated, 125mA-Output, Charge-Pump DC-DC Inverter

## ABSOLUTE MAXIMUM RATINGS

|   |                                     |  |   |
|---|-------------------------------------|--|---|
| IN .....  | -0.3V to +6V                        | Continuous Power Dissipation ( $T_A = +70^\circ\text{C}$ )         |   |
| CAP+, FB, LIN/SKIP .....                            | -0.3V to ( $V_{IN} + 0.3\text{V}$ ) | (derate 5.88mW/ $^\circ\text{C}$ above $+70^\circ\text{C}$ ) ..... | 450mW                                       |
| SHDN .....  | -0.3V to +6V                        | Operating Temperature Range .....                                  | $-40^\circ\text{C}$ to $+85^\circ\text{C}$  |
| OUT, CAP- .....                                     | -6V to +0.3V                        | Junction Temperature .....   | $+150^\circ\text{C}$                        |
| Continuous Output Current .....                     | 135mA                               | Storage Temperature Range .....                                    | $-65^\circ\text{C}$ to $+160^\circ\text{C}$ |
| Output Short-Circuit Duration to GND (Note 1) ..... | 1sec                                | Lead Temperature (soldering, 10sec) .....                          | $+300^\circ\text{C}$                        |

**Note 1:** Shorting OUT to IN may damage the device and should be avoided.

Stresses beyond those listed under "Absolute Maximum Ratings" may cause permanent damage to the device. These are stress ratings only, and functional operation of the device at these or any other conditions beyond those indicated in the operational sections of the specifications is not implied. Exposure to absolute maximum rating conditions for extended periods may affect device reliability.

## ELECTRICAL CHARACTERISTICS

( $V_{IN} = V_{SHDN} = +5\text{V}$ ,  $C_{IN} = 10\mu\text{F}$ ,  $C_{OUT} = 22\mu\text{F}$ ,  $C_{FLY} = 2.2\mu\text{F}$ ,  $T_A = -40^\circ\text{C}$  to  $+85^\circ\text{C}$ , unless otherwise noted. Typical values are at  $T_A = +25^\circ\text{C}$ .) (Note 2)

| PARAMETER                                    | SYMBOL           | CONDITIONS  |                               | MIN   | TYP   | MAX   | UNITS         |
|--|------------------|---|-------------------------------|-------|-------|-------|---------------|
| Input Voltage Range                          | $V_{IN}$         | LIN/SKIP = GND (Skip mode)  |                               | 2.0   |       | 5.5   | V             |
|  |                  | LIN/SKIP = IN (LIN mode)  |                               | 2.7   |       | 5.5   |               |
| Minimum Output Voltage                       | $V_{OUT}$        | LIN/SKIP = GND  |                               |       | 0     |       | V             |
|  |                  | LIN/SKIP = IN   |                               | -1.5  |       |       |               |
| Maximum Output Current                       | $I_{OUT(MAX)}$   |   |                               | 125   |       |       | mA            |
| Output Voltage                               | $V_{OUT}$        | R1 = 100k $\Omega$ , $\pm 1\%$ ,<br>R2 = 60.4k $\Omega$ , $\pm 1\%$ ,<br>$I_{OUT} = 0\text{mA}$ to<br>125mA, Figure 1 | LIN/SKIP = IN<br>(LIN mode)   | -2.90 | -3.02 | -3.15 | V             |
|  |                  |   | LIN/SKIP = GND<br>(Skip mode) | -2.92 | -3.02 | -3.12 |               |
| Quiescent Current ( $I_{IN}$ Current)        | $I_Q$            | $V_{FB} = -100\text{mV}$ , $V_{OUT} = -3\text{V}$ ,<br>LIN/SKIP = IN (LIN mode)                                       |                               |       | 8     | 16    | mA            |
|  |                  | $V_{FB} = -25\text{mV}$ , $V_{OUT} = -3\text{V}$ ,<br>LIN/SKIP = GND (Skip mode)                                      |                               |       | 0.035 | 0.2   |               |
| Shutdown Current ( $I_{IN}$ Current)         | $I_{SHDN}$       | SHDN = GND  |                               |       | 0.1   | 1     | $\mu\text{A}$ |
| Line Regulation                              | $\Delta V_{LNR}$ | $V_{IN} = 4.5\text{V}$ to $5.5\text{V}$ ,<br>Figure 4,<br>$V_{REF} \neq V_{IN}$                                       | LIN/SKIP = IN<br>(LIN mode)   |       | 0.01  |       | %V            |
|  |                  |   | LIN/SKIP = GND<br>(Skip mode) |       | 1     |       |               |
| Load Regulation                              | $\Delta V_{LDR}$ | $I_{OUT} = 25\text{mA}$ to<br>125mA, Figure 1   | LIN/SKIP = IN<br>(LIN mode)   |       | 0.01  |       | %mA           |
|  |                  |   | LIN/SKIP = GND<br>(Skip mode) |       | 0.005 |       |               |
| Open-Loop Output Resistance (Dropout)        | $R_O$            | LIN/SKIP = GND (Skip mode)  |                               |       | 3.5   | 10    | $\Omega$      |
| Output Resistance to Ground in Shutdown Mode |                  | SHDN = GND  |                               |       | 1     | 5     | $\Omega$      |

# Regulated, 125mA-Output, Charge-Pump DC-DC Inverter

MAX1673

## ELECTRICAL CHARACTERISTICS (continued)

( $V_{IN} = V_{SHDN} = +5V$ ,  $C_{IN} = 10\mu F$ ,  $C_{OUT} = 22\mu F$ ,  $C_{FLY} = 2.2\mu F$ ,  $T_A = -40^\circ C$  to  $+85^\circ C$ , unless otherwise noted. Typical values are at  $T_A = +25^\circ C$ .) (Note 2)

| PARAMETER                              | SYMBOL    | CONDITIONS                           |                  | MIN                 | TYP | MAX                 | UNITS   |
|--|-----------|--------------------------------------|------------------|---------------------|-----|---------------------|---------|
| Switching Frequency<br>(LIN Mode)      | $f_{OSC}$ | $T_A = +25^\circ C$                  |                  | 250                 | 350 | 460                 | kHz     |
|  |           | $T_A = -40^\circ C$ to $+85^\circ C$ |                  | 205                 |     | 515                 |         |
| FB Threshold                           | $V_{FBT}$ | LIN/SKIP = GND (Skip mode)           |                  | -25                 | 0   | 25                  | mV      |
| FB Input Bias Current                  | $I_{FB}$  | LIN/SKIP = IN<br>(LIN mode)          | $V_{FB} = -25mV$ |                     | 150 | 600                 | nA      |
|  |           | LIN/SKIP = GND<br>(Skip mode)        |                  |                     | 1   | 100                 |         |
| Input Bias Current<br>(SHDN, LIN/SKIP) |           |                                      |                  |                     |     | 1                   | $\mu A$ |
| Logic High Input<br>(SHDN, LIN/SKIP)   | $V_{IH}$  | $2V \leq V_{IN} \leq 5.5V$           |                  | $0.7 \times V_{IN}$ |     |                     | V       |
| Logic Low Input<br>(SHDN, LIN/SKIP)    | $V_{IL}$  | $2V \leq V_{IN} \leq 5.5V$           |                  |                     |     | $0.3 \times V_{IN}$ | V       |

**Note 2:** Specifications to  $-40^\circ C$  are guaranteed by design, not production tested.

# Regulated, 125mA-Output, Charge-Pump DC-DC Inverter

## Typical Operating Characteristics

(Circuit of Figure 1,  $V_{IN} = +5V$ ,  $C_{FLY} = 2.2\mu F$ ,  $C_{OUT} = 22\mu F$ ,  $T_A = +25^\circ C$ , unless otherwise noted.)

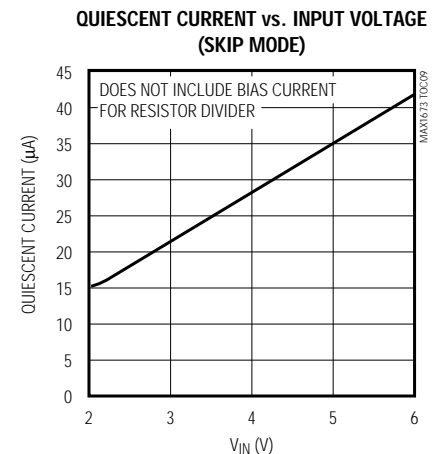
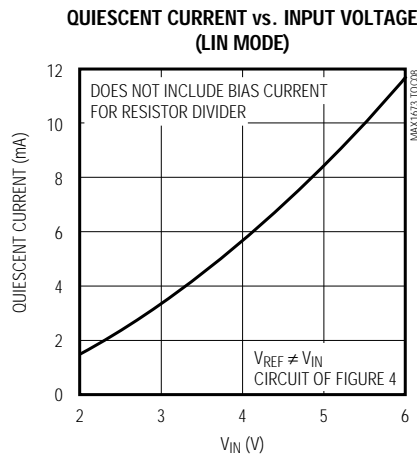
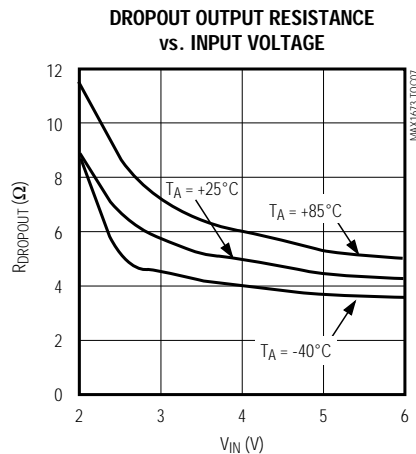
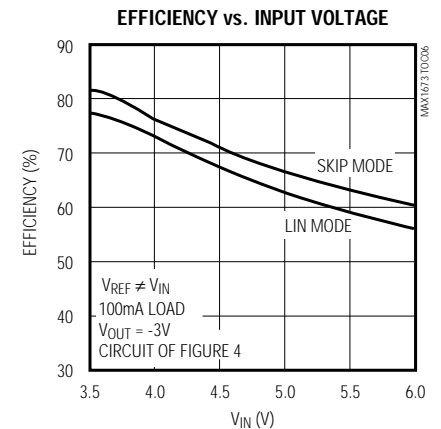
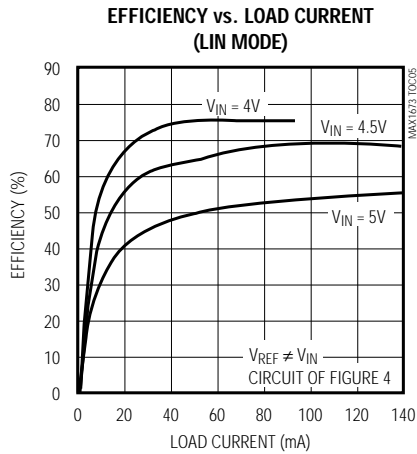
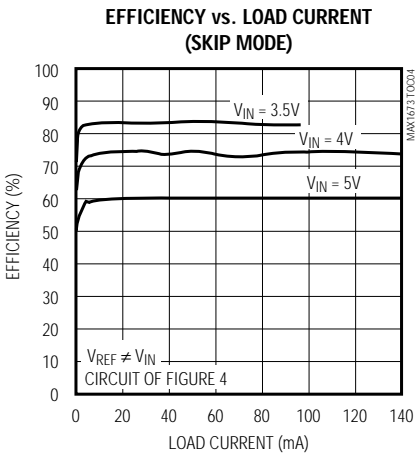
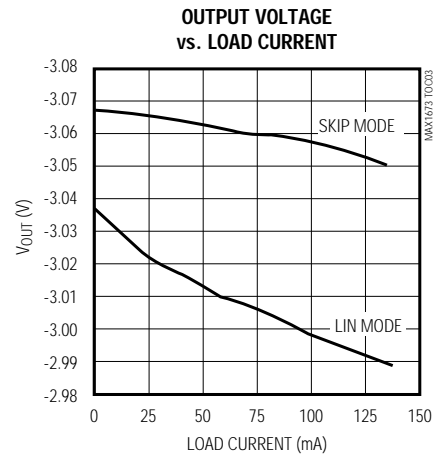
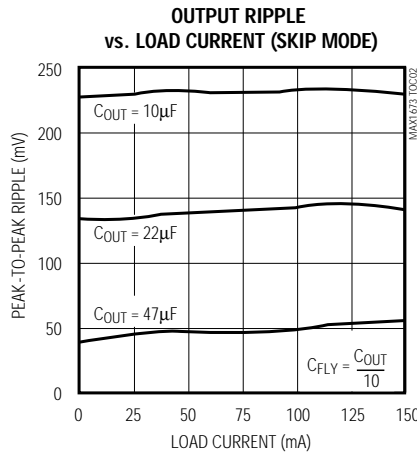
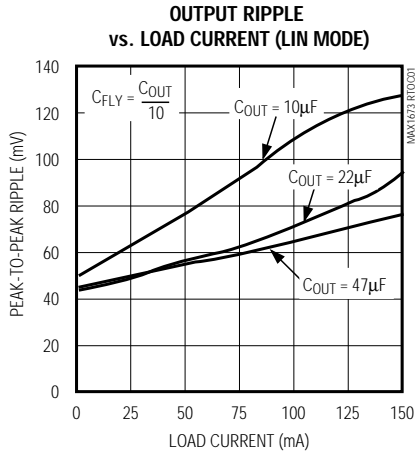

# Regulated, 125mA-Output, Charge-Pump DC-DC Inverter

MAX1673

## Typical Operating Characteristics (continued)

(Circuit of Figure 1,  $V_{IN} = +5V$ ,  $C_{FLY} = 2.2\mu F$ ,  $C_{OUT} = 22\mu F$ ,  $T_A = +25^\circ C$ , unless otherwise noted.)

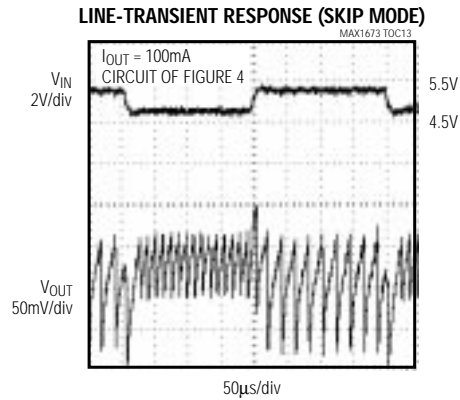
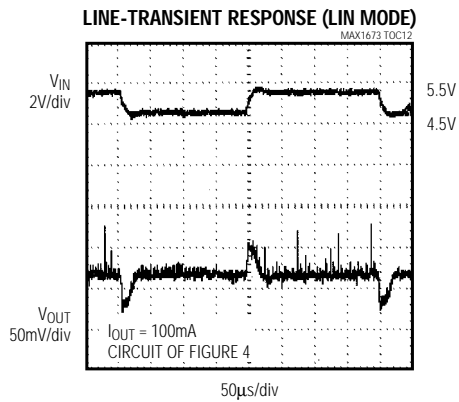
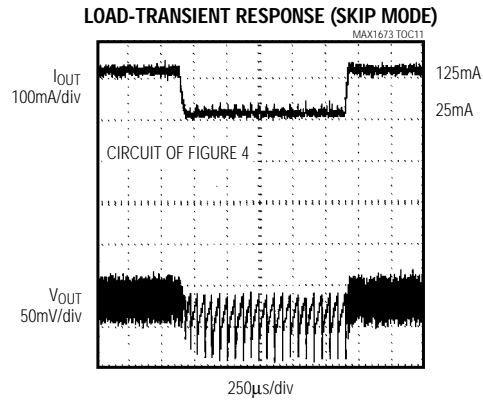
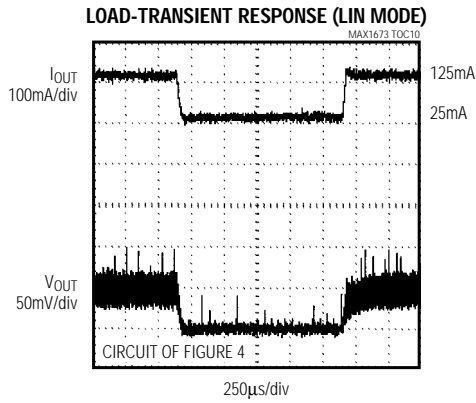

# Regulated, 125mA-Output, Charge-Pump DC-DC Inverter

## Pin Description

| PIN | NAME     | FUNCTION  |
|-----|----------|---|
| 1   | LIN/SKIP | Regulation-Mode Select Input. Driving LIN/SKIP high or connecting it to IN selects LIN mode, with regulation accomplished by modulating switch resistance. Driving LIN/SKIP low or connecting it to GND selects Skip mode, where the device regulates by skipping charge-pump pulses. |
| 2   | CAP+     | Positive Terminal of Flying Capacitor   |
| 3   | CAP-     | Negative Terminal of Flying Capacitor   |
| 4   | SHDN     | Shutdown Control Input. Drive SHDN low to shut down the MAX1673. Connect SHDN to IN for normal operation. OUT connects to GND through a 1Ω (typical) resistor in shutdown mode.   |
| 5   | OUT      | Inverting Charge-Pump Output  |
| 6   | FB       | Feedback Input. Connect FB to a resistor-divider from IN (or other reference source) to OUT for regulated output voltages (Figures 1 and 4).  |
| 7   | GND      | Ground  |
| 8   | IN       | Power-Supply Positive Voltage Input   |

## Detailed Description

The MAX1673 new-generation, high-output-current, regulated charge-pump DC-DC inverter provides up to 125mA. Designed specifically for compact applications, a complete regulating circuit requires only three small capacitors and two resistors. The MAX1673 employs On-Demand™ regulation circuitry, providing output regulation modes optimized for either lowest output noise or lowest supply current. In addition, the MAX1673 includes shutdown control.

In Linear (LIN) mode or when heavily loaded in Skip mode, the charge pump runs continuously at 350kHz. During one-half of the oscillator period, switches S1 and S2 close (Figure 2), charging the transfer capacitor (C<sub>FLY</sub>) to the input voltage (CAP- = GND, and CAP+ = IN). During the other half cycle, switches S3 and S4 close (Figure 3), transferring the charge on C<sub>FLY</sub> to the output capacitor (CAP+ = GND, CAP- = OUT).

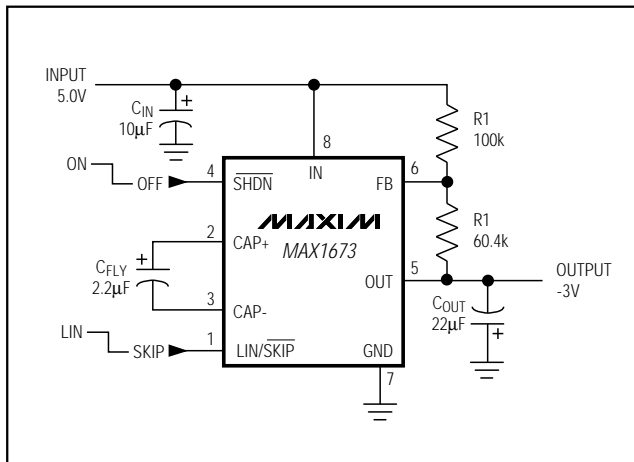

Figure 1. Standard Application Circuit

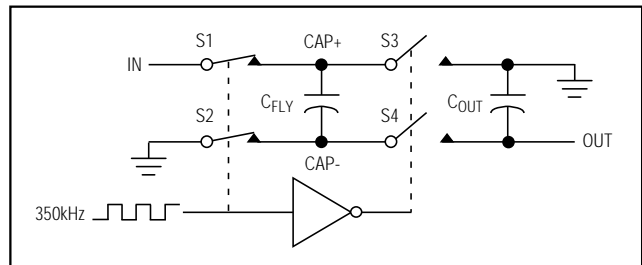

Figure 2. Charging C<sub>FLY</sub>

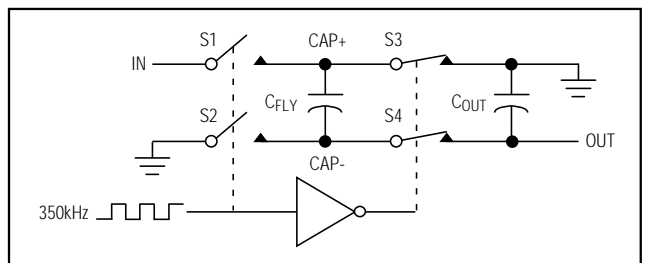

Figure 3. Transferring Charge on C<sub>FLY</sub> to C<sub>OUT</sub>

# Regulated, 125mA-Output, Charge-Pump DC-DC Inverter

MAX1673

## Linear Mode (Constant-Frequency Mode)

In LIN mode ( $\overline{\text{LIN}}/\overline{\text{SKIP}} = \text{IN}$ ), the charge pump runs continuously at 350kHz. The MAX1673 controls the charge on  $C_{\text{FLY}}$  by varying the gate drive on S1 (Figure 2). When the output voltage falls,  $C_{\text{FLY}}$  charges faster due to increased gate drive. Since the device switches continuously, the regulation scheme minimizes output ripple, the output noise contains well-defined frequency components, and the circuit requires much smaller external capacitors than in Skip mode for a given output ripple.\* However, LIN mode is less efficient than Skip mode due to higher operating current (8mA typical).

## Skip Mode

In Skip mode ( $\overline{\text{LIN}}/\overline{\text{SKIP}} = \text{GND}$ ), the device switches only as needed to maintain regulation on FB. Switching cycles are skipped until the voltage on FB rises above GND. Skip mode has higher output noise than LIN mode, but minimizes operating current.

## Shutdown Mode

When  $\overline{\text{SHDN}}$  (a CMOS-compatible input) is driven low, the MAX1673 enters low-power shutdown mode. Charge-pump switching action halts and an internal  $1\Omega$  switch pulls  $V_{\text{OUT}}$  to ground. Connect  $\overline{\text{SHDN}}$  to IN or drive high for normal operation.

\*See Output Ripple vs. Load Current in *Typical Operating Characteristics*.

## Applications Information

### Resistor Selection (Output Voltage Selection)

The accuracy of  $V_{\text{OUT}}$  depends on the accuracy of the voltage biasing the voltage-divider network ( $R_1$ ,  $R_2$ ). Use a separate reference voltage if  $V_{\text{IN}}$  is an unregulated voltage or if greater accuracy is desired (Figure 4).

Adjust the output voltage from  $-1.5\text{V}$  to  $-V_{\text{IN}}$  in LIN mode or  $0\text{V}$  to  $-V_{\text{IN}}$  in Skip mode with external resistors  $R_1$  and  $R_2$  as shown in Figures 1 and 4. In either regulating mode (LIN or Skip), FB servos to  $0\text{V}$ . Use the following equations to select  $R_1$  and  $R_2$  for the desired output voltage:

$$V_{\text{OUT}} = -V_{\text{REF}} \frac{R_2}{R_1}$$

where  $V_{\text{REF}}$  can be either  $V_{\text{IN}}$  or some other positive reference source.

Typically, choose a voltage-divider current of  $50\mu\text{A}$  to minimize the effect of FB input current:

$$R_1 = V_{\text{REF}} / 50\mu\text{A}$$

$$R_2 = -V_{\text{OUT}} / 50\mu\text{A}$$

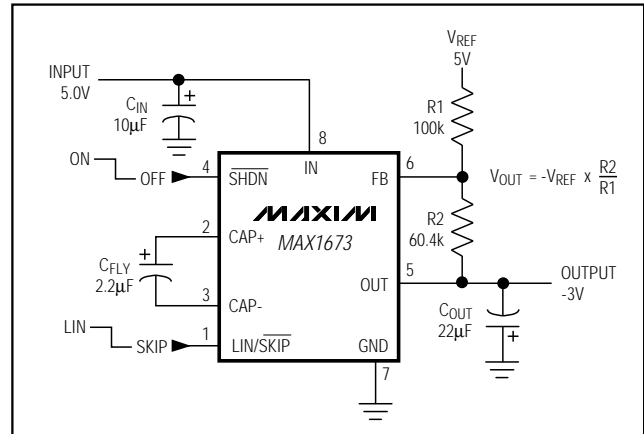

Figure 4. Separate  $V_{\text{REF}}$  for Voltage Divider

## Capacitor Selection

A  $C_{\text{FLY}}$  value of  $1\mu\text{F}$  or more is sufficient to supply the specified load current. However, for minimum ripple in Skip mode, this value may need to be increased. Maxim recommends  $2.2\mu\text{F}$ .

Surface-mount ceramic capacitors are preferred for  $C_{\text{FLY}}$ , due to their small size, low cost, and low equivalent series resistance (ESR). To ensure proper operation over the entire temperature range, choose ceramic capacitors with X7R (or equivalent) low-temperature-coefficient (tempco) dielectrics. See Table 1 for a list of suggested capacitor suppliers.

The output capacitor stores the charge transferred from the flying capacitor and services the load between oscillator cycles. A good general rule is to make the output capacitance at least ten times greater than that of the flying capacitor.

When in Skip mode, output ripple depends mostly on two parameters: charge transfer between the capacitance values of  $C_{\text{FLY}}$  and  $C_{\text{OUT}}$ , and the ESR of  $C_{\text{OUT}}$ . The ESR ripple contribution occurs as  $C_{\text{OUT}}$  charges. The charging current creates a negative voltage pulse across the capacitor's ESR that recedes as  $C_{\text{OUT}}$  charges. At equilibrium, when the voltage on  $C_{\text{FLY}}$  approaches that on  $C_{\text{OUT}}$ , no charging current flows. Secondly, the ripple contribution due to charge transfer between capacitors creates a pulse as charge flows to  $C_{\text{OUT}}$ . Adding the two terms does not determine peak-to-peak ripple because their peaks do not occur at the same time. It is best to use only the dominant term. The expression for the ripple component predominantly due to  $C_{\text{OUT}}$  ESR is:

# Regulated, 125mA-Output, Charge-Pump DC-DC Inverter

$$V_{\text{RIPPLE(ESR)}} = 8 \left( \frac{V_{\text{IN}} - |V_{\text{OUT}}|}{f_{\text{OSC}}} \right) \left( \frac{\text{ESR}_{\text{COUT}}}{R_{\text{OUT}}^2 C_{\text{FLY}}} \right)$$

The expression for the ripple component predominantly due to charge transfer is:

$$V_{\text{RIPPLE(ESR)}} = 2 \left( \frac{V_{\text{IN}} - |V_{\text{OUT}}|}{f_{\text{OSC}}} \right) \left( \frac{1}{R_{\text{OUT}} (C_{\text{FLY}} + C_{\text{OUT}})} \right)$$

where  $C_{\text{FLY}}$  and  $C_{\text{OUT}}$  are their respective capacitance values,  $\text{ESR}_{\text{COUT}}$  is the equivalent series resistance of  $C_{\text{OUT}}$ ,  $R_{\text{OUT}}$  is the MAX1673 open-loop output impedance (typically  $3.5\Omega$ ), and  $f_{\text{OSC}}$  is the MAX1673 switching frequency (typically 350kHz). If  $\text{ESR}_{\text{COUT}}$  is very small, as is likely when ceramic capacitors are used,  $V_{\text{RIPPLE(TRANSFER)}}$  dominates. If ESR is relatively large, as with low-cost tantalum capacitors, then  $V_{\text{RIPPLE(ESR)}}$  dominates.

When operating in LIN mode, use the following equation to approximate peak-to-peak output voltage ripple:

$$V_{\text{RIPPLE}} = \frac{I_{\text{OUT}}}{2 f_{\text{OSC}} C_{\text{OUT}}} + 2 I_{\text{OUT}} \text{ESR}_{\text{COUT}}$$

where  $C_{\text{OUT}}$  is the output capacitor value,  $\text{ESR}_{\text{COUT}}$  is the output capacitor's ESR, and  $f_{\text{OSC}}$  is the MAX1673 oscillator frequency (typically 350kHz).

To ensure LIN mode stability over the entire temperature range, choose a low-ESR (no more than  $100\text{m}\Omega$ ) output capacitance using the following equation:

$$C_{\text{OUT}} = 75 \times 10^{-6} \left( \frac{R_1}{R_1 + R_2} \right) \sqrt{I_{\text{OUT}}}$$

where  $C_{\text{OUT}}$  is the output capacitor value, and  $f_{\text{MIN}}$  is the minimum oscillator frequency (250kHz). See Table 1 for a list of suggested capacitor suppliers.

## Layout Considerations

The MAX1673's high oscillator frequency requires good layout technique, which ensures stability and helps maintain the output voltage under heavy loads. Take the following steps to ensure good layout:

- Mount all components as close together as possible.
- Place the feedback resistors R1 and R2 close to the FB pin, and minimize the PC trace length at the FB circuit node.
- Keep traces short to minimize parasitic inductance and capacitance.
- Use a ground plane.

## Chip Information

TRANSISTOR COUNT: 386

SUBSTRATE CONNECTED TO: IN

**Table 1. Partial Listing of Capacitor Vendors**

| PRODUCTION METHOD      | MANUFACTURER | SERIES     | PHONE          | FAX            |
|------------------------|--------------|------------|----------------|----------------|
| Surface-Mount Tantalum | AVX          | TPS        | (803) 946-0690 | (803) 448-2170 |
|                        | Matsuo       | 267        | (714) 969-2491 | (714) 960-6492 |
|                        | Sprague      | 593D, 595D | (603) 224-1961 | (603) 224-1430 |
| Surface-Mount Ceramic  | AVX          | X7R        | (803) 946-0590 | (803) 626-3123 |
|                        | Matsuo       | X7R        | (714) 969-2491 | (714) 960-6492 |

Maxim cannot assume responsibility for use of any circuitry other than circuitry entirely embodied in a Maxim product. No circuit patent licenses are implied. Maxim reserves the right to change the circuitry and specifications without notice at any time.

8 \_\_\_\_\_ Maxim Integrated Products, 120 San Gabriel Drive, Sunnyvale, CA 94086 408-737-7600